



baseboxes

halo basebox

main features

A patented fixing consists of a single stainless steel cap head allen bolt, tightens a continuous stainless steel band within the bodyshell into a purpose made recess in the cast aluminium circular lid. Once tightened the band exerts even pressure all round the base housing to provide a very effective vandal resistant fixing.

Within the patented light tray a cooling fan allows a consistent even temperature. Cool air is drawn over the fluorescent tubes maximising output and efficiency. Hot air is dispelled against the inner walls utilising the basebox as a heat sink.

The Halo Light Tray and Lid will retro-fit into an existing Haldo Basebox.



Light tray



Domed Lid

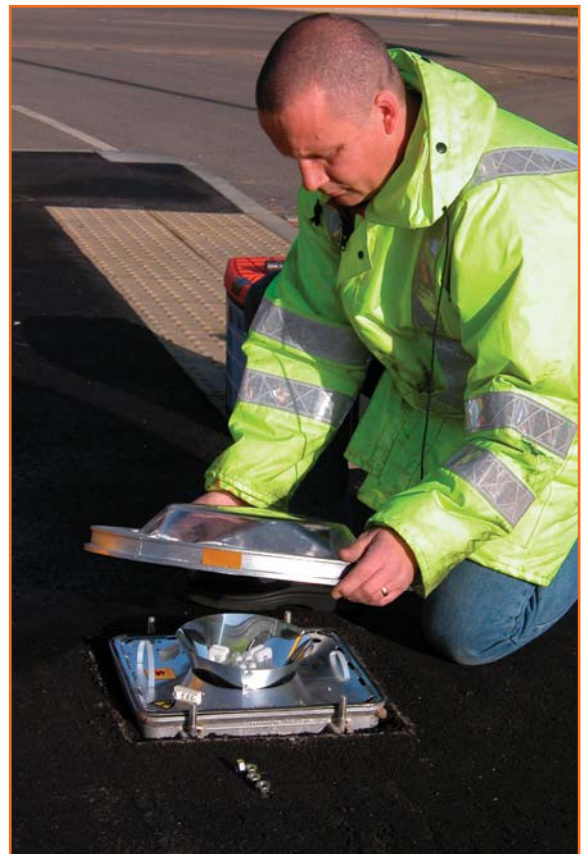

HALDO



baseboxes

halo basebox

specification

Basebox (fig. 1)

Die cast aluminium LM6 basebox complete with lid, domed lens, light tray and earth terminal. Inclusive of lamps.

Basebox c/w domed lid Part Numbers (fig. 2)

- C6/HAL/19B 3 x 10 watt light tray, standard ballast
- C6/HAL/19D 3 x 10 watt light tray, electronic ballast
- C6/HAL/19F 4 x 10 watt light tray, standard ballast
- C6/HAL/19H 4 x 10 watt light tray, electronic ballast

Light Tray (fig. 3)

Using 3 or 4 miniature fluorescent tubes (depending on signface size) the central parabolic reflector is mounted onto a removable light tray. Lifting out the light tray simultaneously disconnects it both mechanically and electrically.

Light Tray Part Numbers

- C6/HAL/16B 3 x 10 watt, standard ballast with fan
- C6/HAL/16D 3 x 10 watt, electronic ballast with fan
- C6/HAL/16F 4 x 10 watt, standard ballast with fan
- C6/HAL/16H 4 x 10 watt electronic ballast with fan

Fixing Tools

- C6/HAL/FB Stainless Steel Fixing Band
- C6/HAL/KY Fixing Band Key

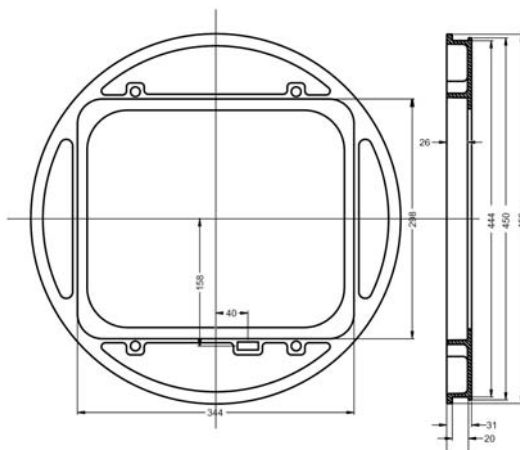
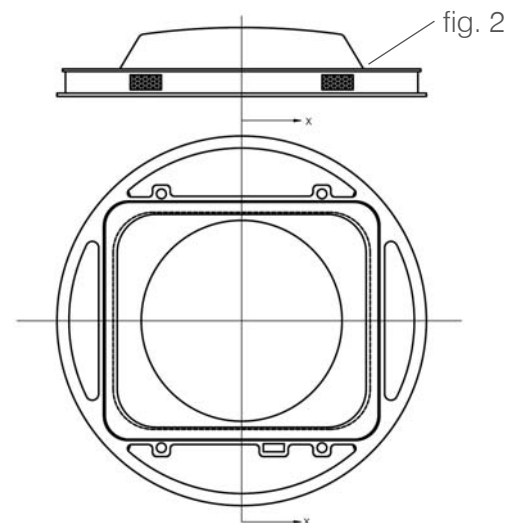
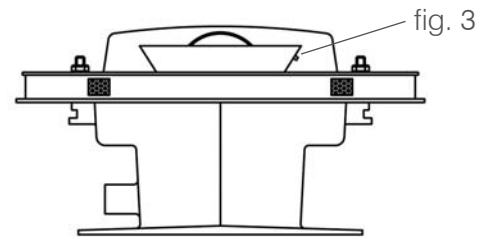
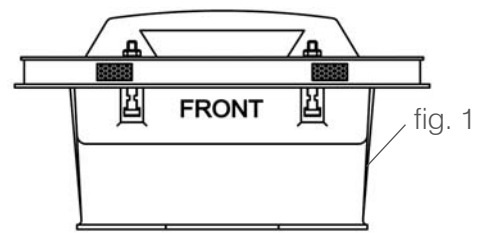

HALDO



Haldo Developments Limited

Western Way Bury St. Edmunds Suffolk IP33 3SP UK

T. +44 (0)1284 754043 F. +44 (0)1284 767260

info@haldo.com

www.haldo.com

Haldo Developments Ltd is a co. registered in England and Wales

Reg no.940159

VAT No. GB 102 351627