



cycle

Tango Cycle Racks

main features

Ideal for sites where bikes of various tyre and handlebar widths will be stored.

Solid construction, resistant to vandalism or theft.

Stands are supplied in parts that can be coupled with connecting pieces for single or double spur installations, with the smallest installation consisting of two spaces.

Easy installation.



Colour Description

Stands are hot dipped galvanised and available in a wide range of RAL colours.

Technical information

Stand is suitable for bikes with various tyre and handlebar widths.

Bikes can be secured against theft with a cable lock or padlock.

Stands are supplied in parts that can be coupled with connecting pieces to allow for increased storage.

Single Spur: Single stands are constructed by a left and right end part and can be extended by connecting pieces.

The smallest stand available consists of two places.

Double Spur: Double stands are constructed by two end parts, and can be extended by connecting pieces.

The smallest stand available consists of four spaces and can be extended as required.

Foundation Bolts are used to secure the stand to the pavement.

Fastening means are supplied.



cycle

Tango Cycle Racks

Measurements

Placement: Bikes are usually placed 60cm centre to centre. A distance of 70cm or 80cm centre to centre is also possible.

Stand Diameter: 42.4mm

Coupling Tubes Diameter: 41.5mm.

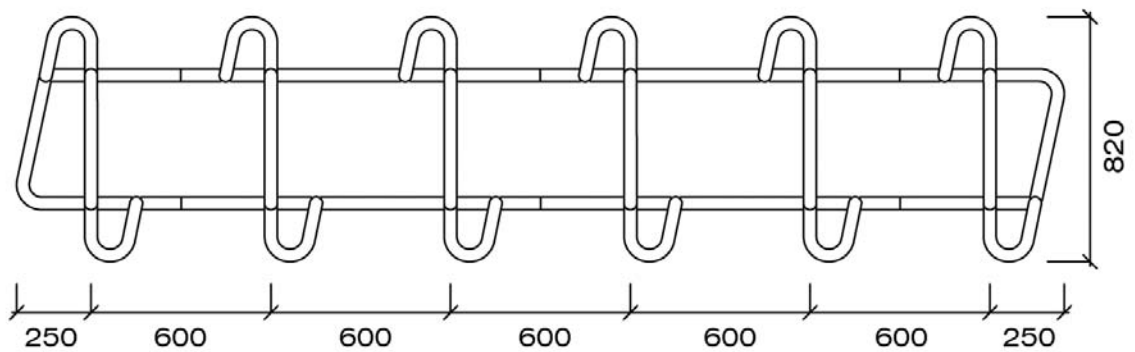
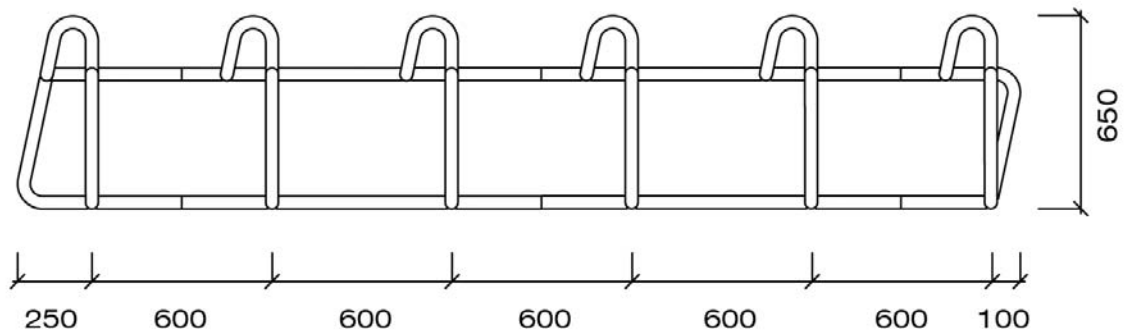
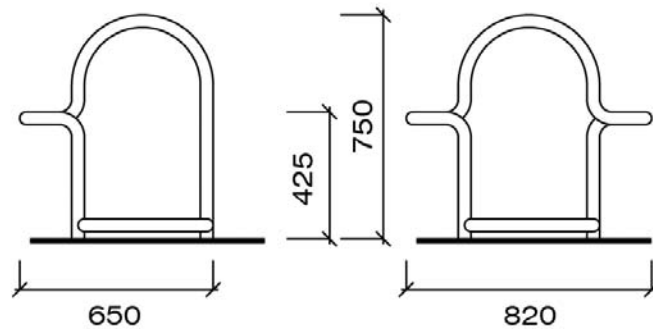

HALDO



Haldo Developments Limited

Western Way Bury St. Edmunds Suffolk IP33 3SP UK

T. +44 (0)1284 754043 F. +44 (0)1284 767260

info@haldo.com

www.haldo.com

Haldo Developments Ltd is a co.
registered in England and Wales

Reg no.940159

VAT No. GB 102 351627